

A-A

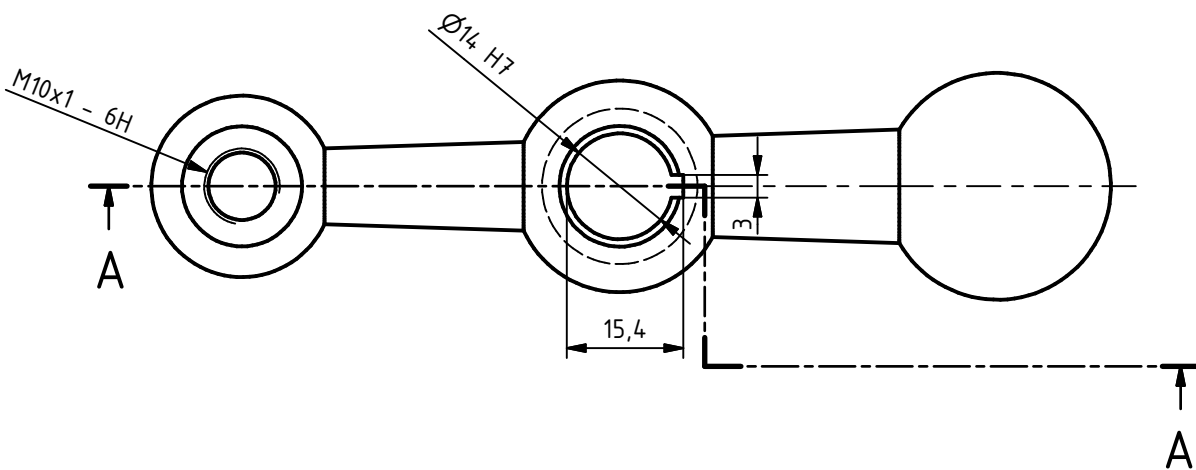

Designed by JoaFonseca	Checked by	Approved by	Date		Date 23-03-2005	A4
JOF			Manivela			
Prov6_35_Maniv			Edition 1	Sheet 1 / 1		

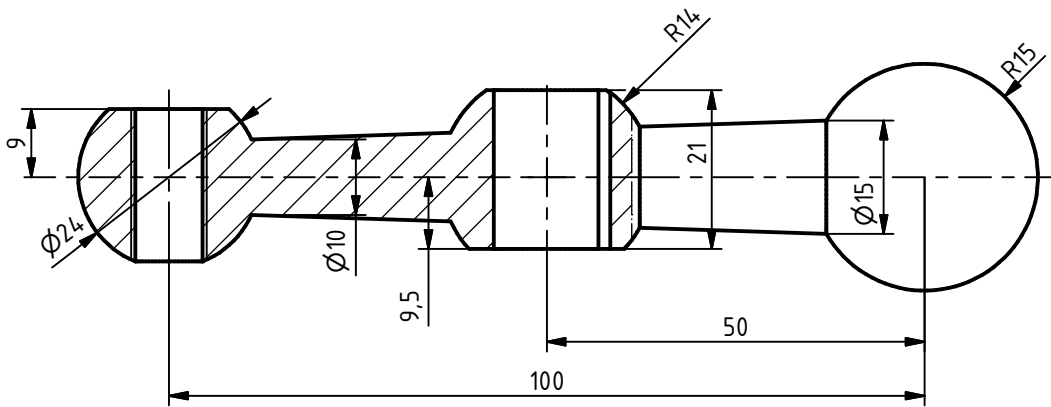
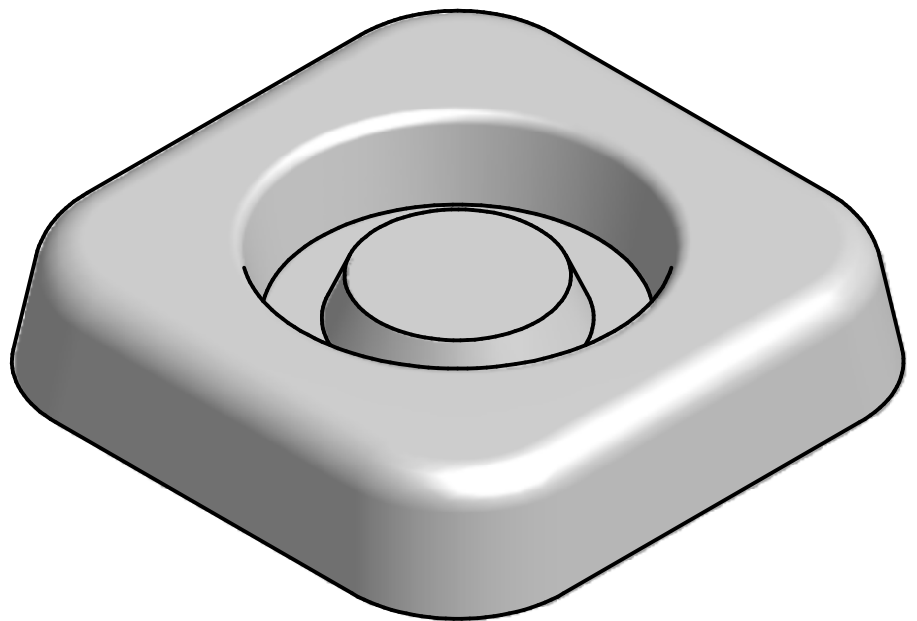
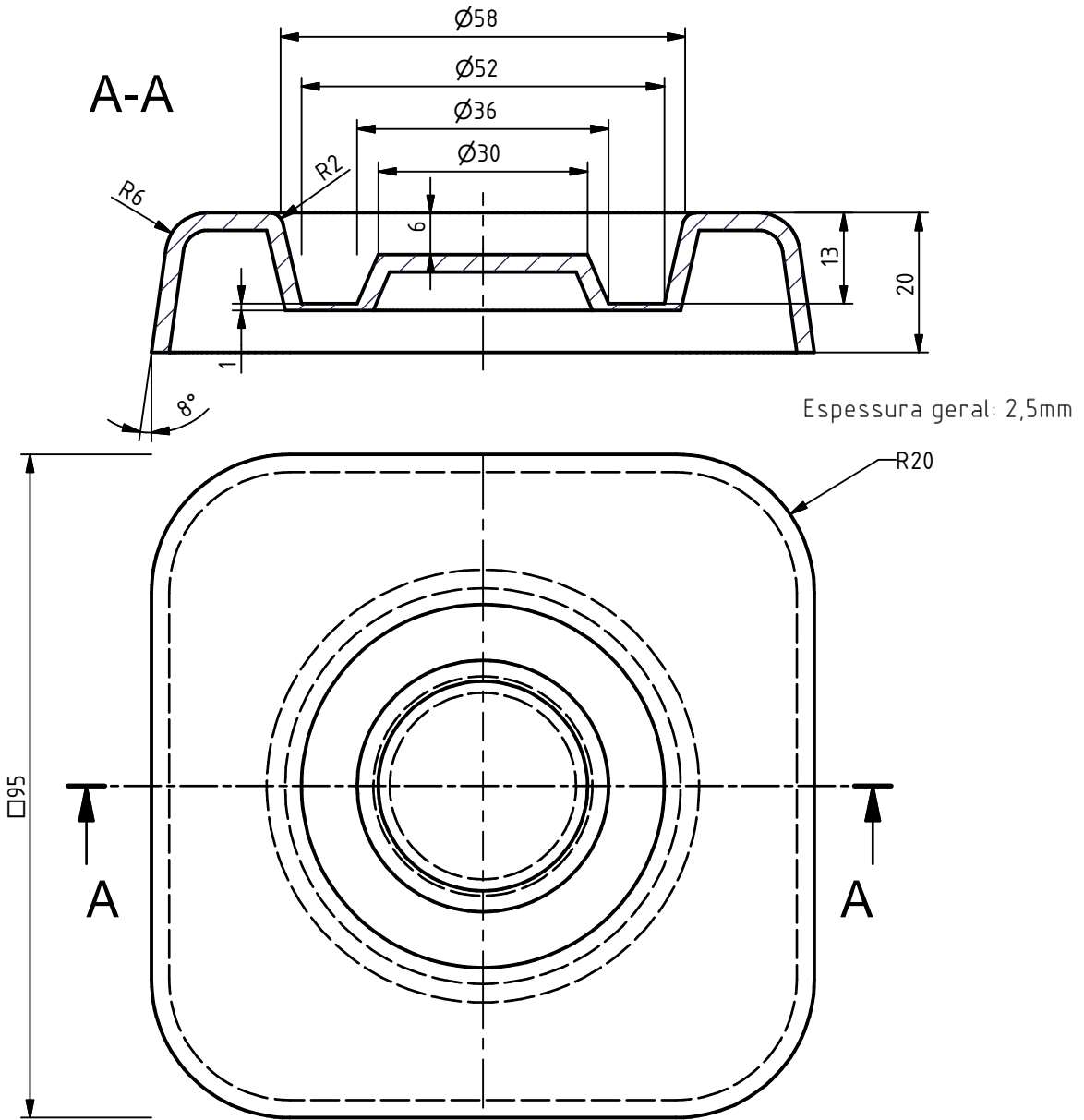

Designed by JoF	Checked by	Approved by - date	Date 10-06-2004	A4
JOF		Exerc de SHELL		
		Shelldiv	Edition 1	Sheet 1 / 1

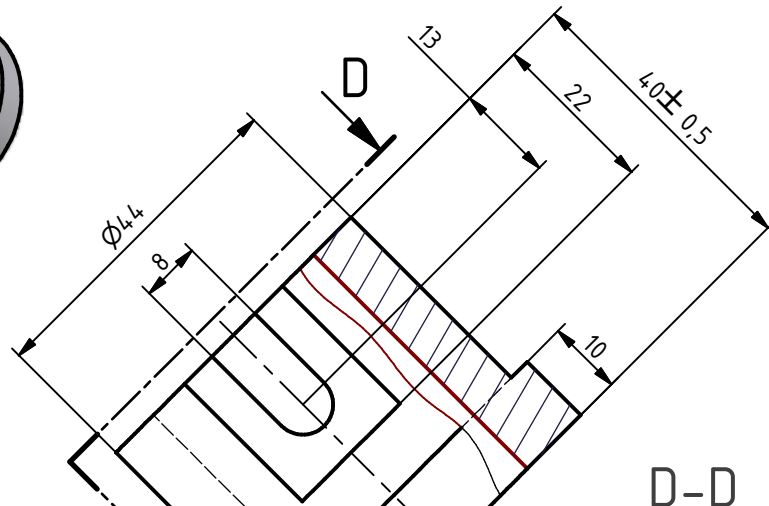
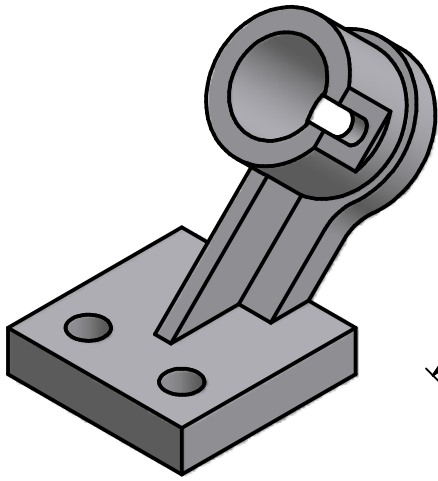

D-D ( 1 : 1 )

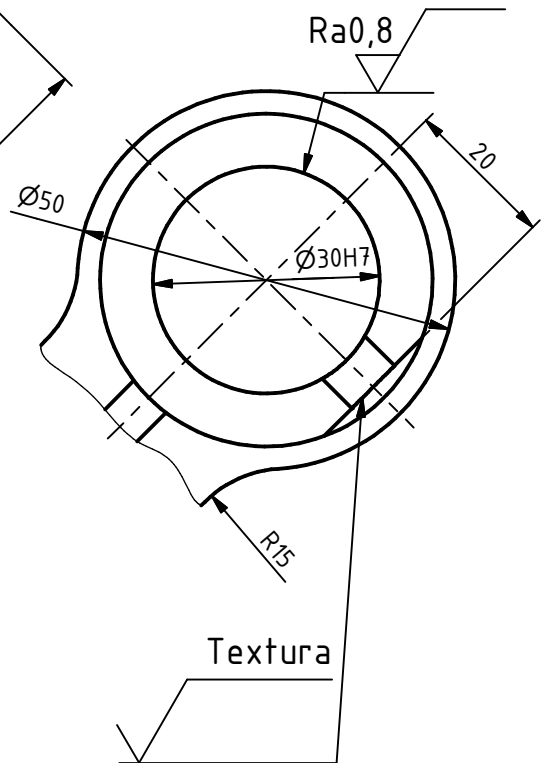

B  

//	0,2	A
----	-----	---

Realize a modelação da peça apresentada.  
 De seguida reproduza este desenho com todas as anotações e cotagem.

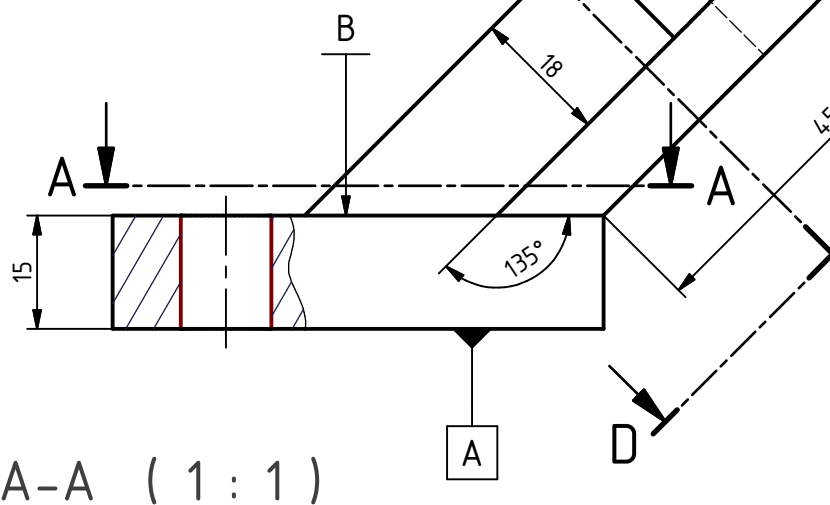

A-A ( 1 : 1 )

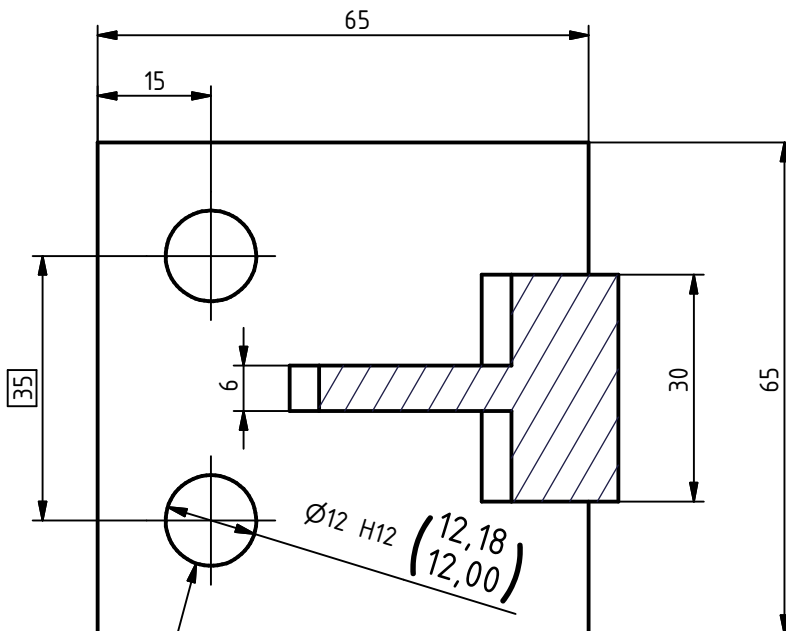

$\phi 0,09$  A

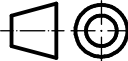
Designed by JoF	Checked by	Approved by	Date 	Date 01-05-2004	A4
JOF			VISTA AUXILIAR 1ª		
			vistauxiliar	Edition 2	Sheet 1 / 1

A

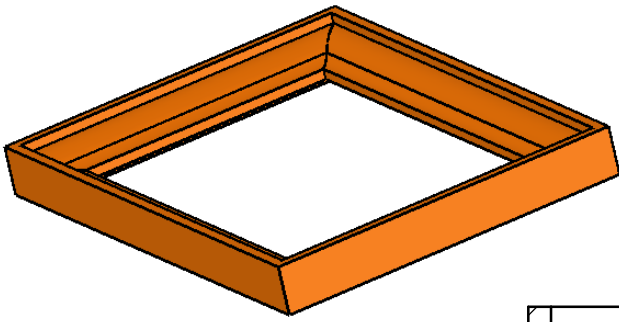

SECTION B-B

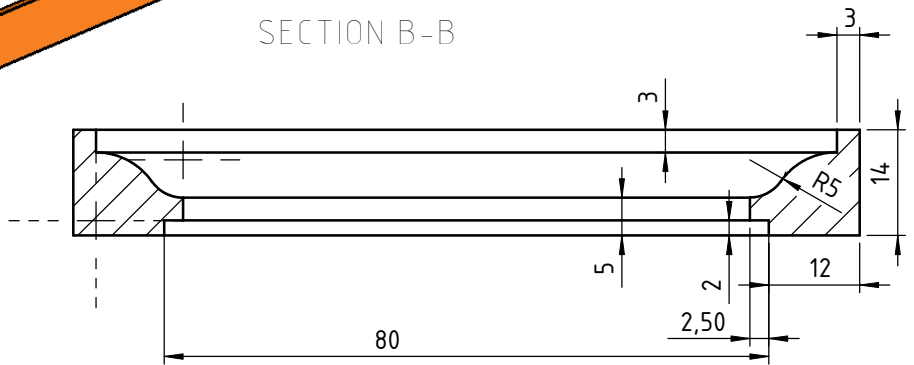

B

C

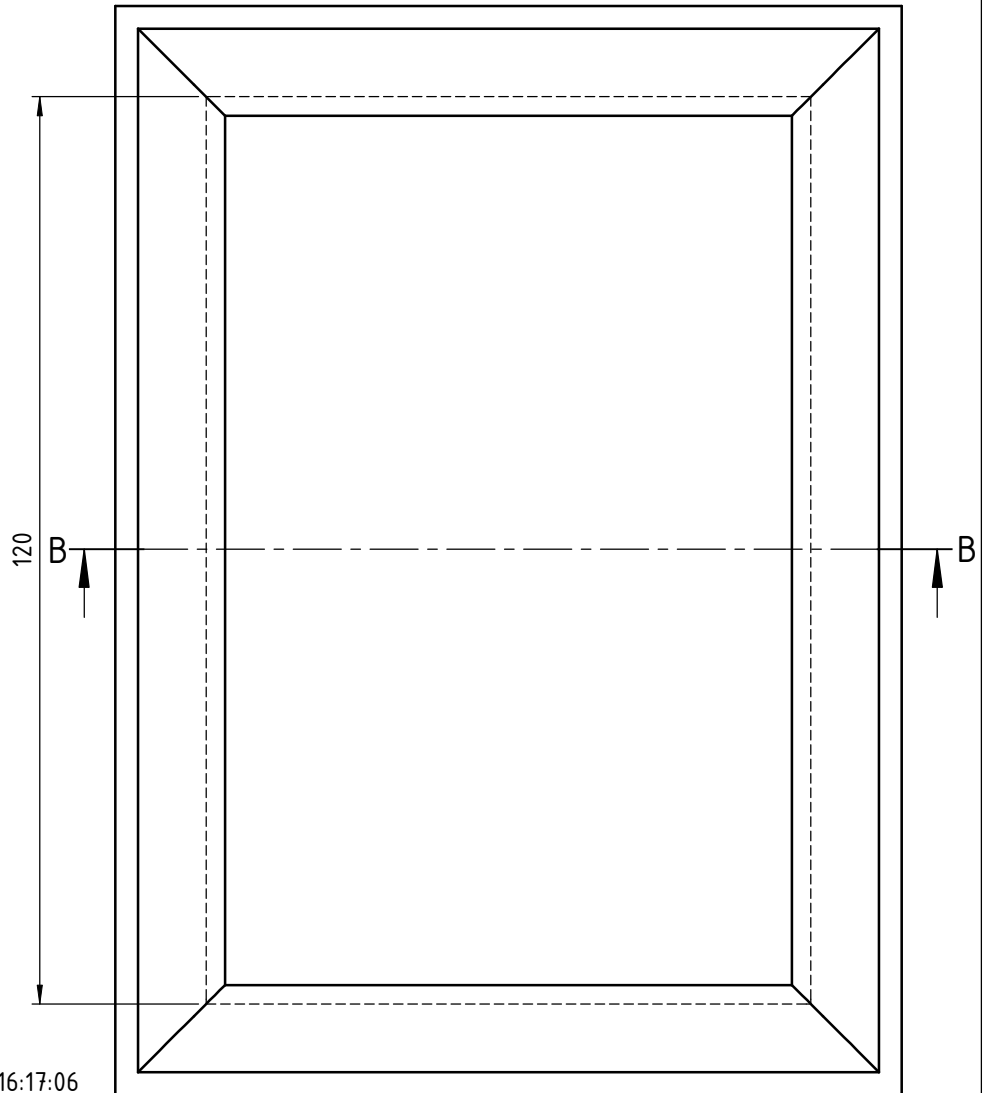

D

E

sexta-feira, 20 de Março de 2009 16:17:06

UNLESS OTHERWISE SPECIFIED: DIMENSIONS ARE IN MILLIMETERS		FINISH:		DEBUR AND BREAK SHARP EDGES		DO NOT SCALE DRAWING		REVISION	
SURFACE FINISH:									
TOLERANCES:									
LINEAR:									
ANGULAR:									
		NAME		SIGNATURE		DATE		TITLE:	
DRAWN								CAIXILHO RECTANG.	
CHK'D									
APPV'D								DWG NO. Caixilho2	
MFG									
Q.A								A4	
						MATERIAL:			
						WEIGHT:		SCALE: 1:1	
								SHEET 1 OF 1	

A-A ( 1 : 1 )

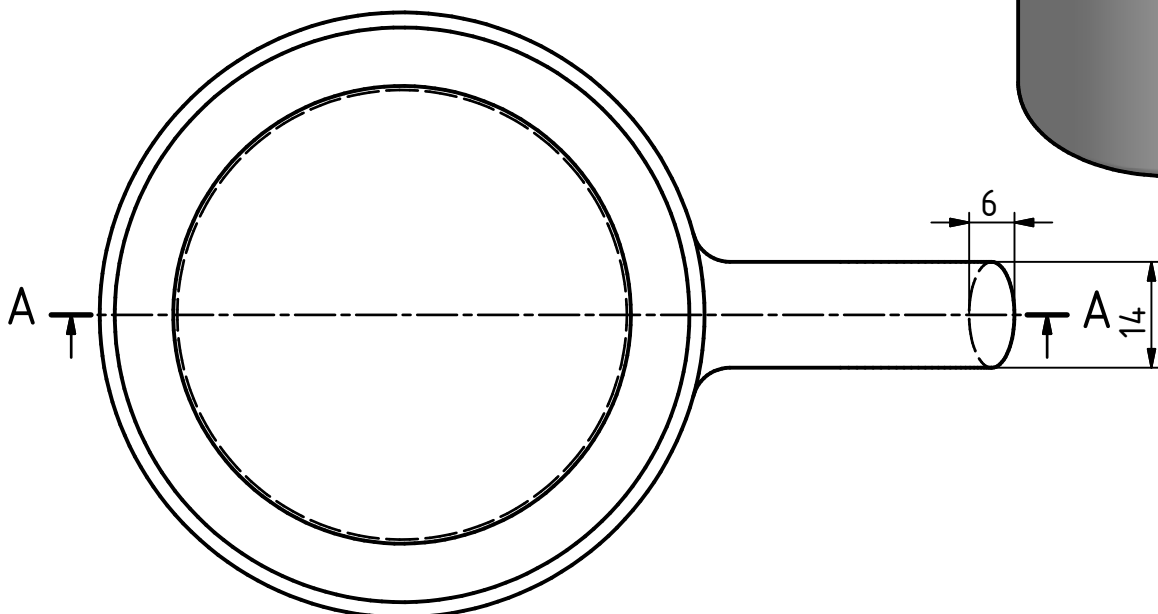
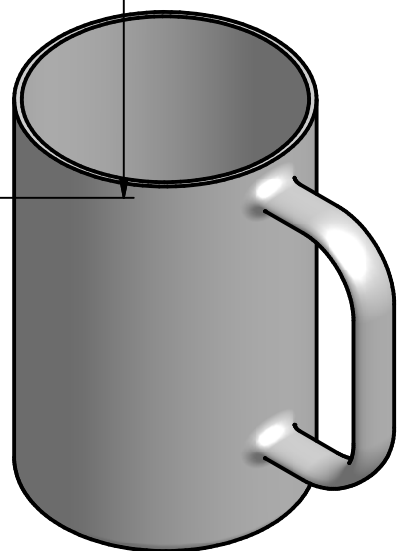
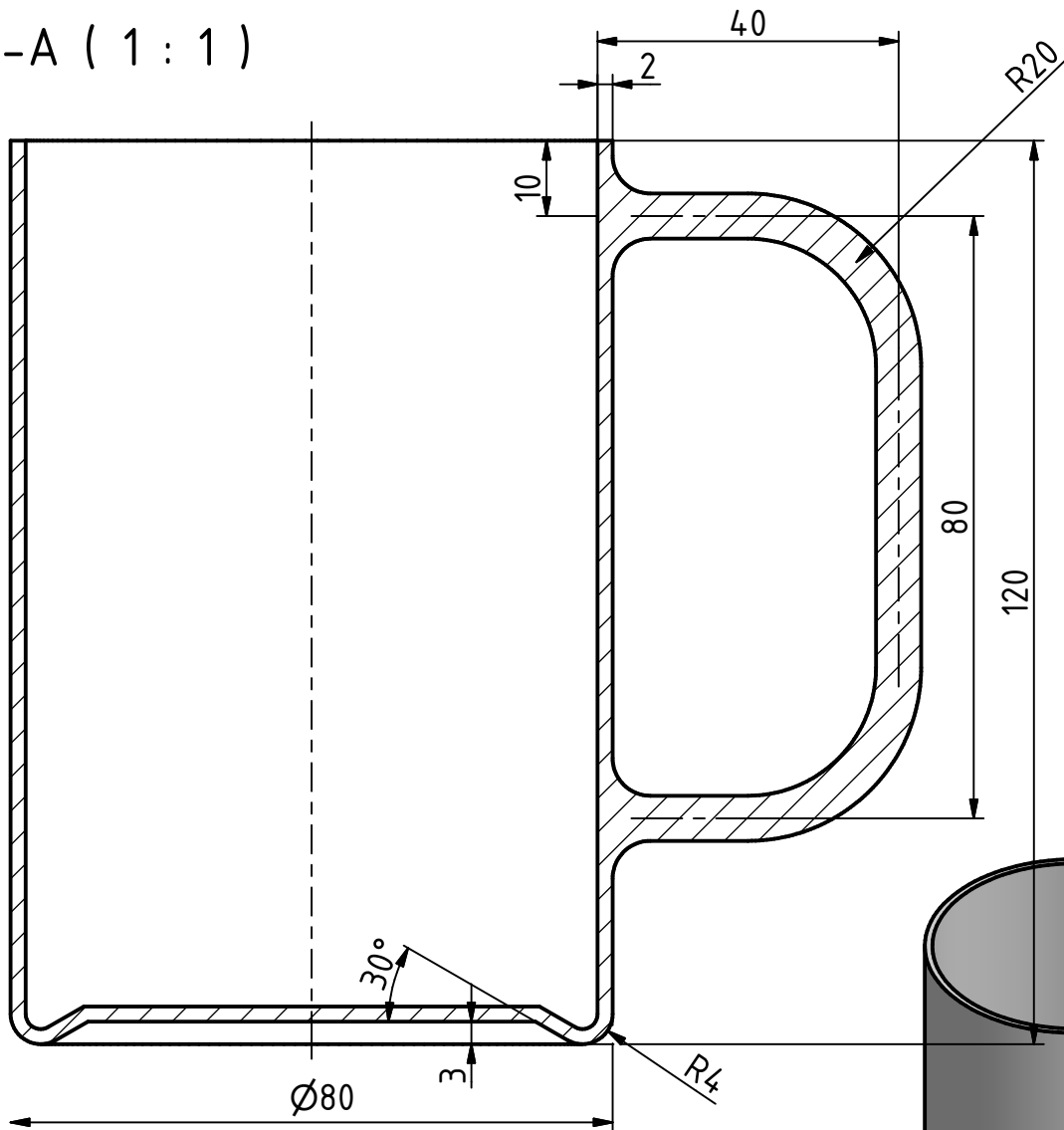

Designed by fonseca	Checked by	Approved by	Date	Date 21-06-2008
JOF		CANECA		
IVR-Caneca		Edition	Sheet 1 / 1	

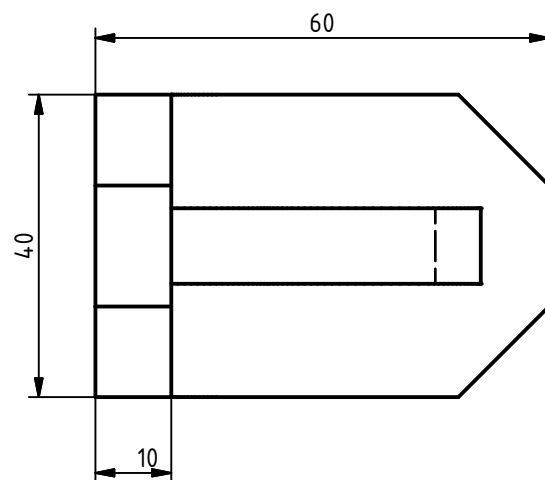
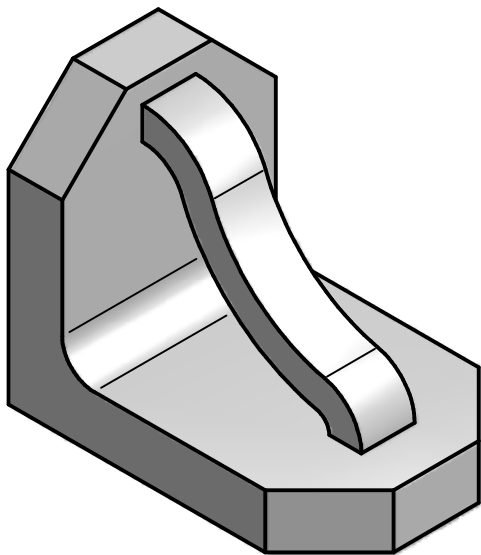
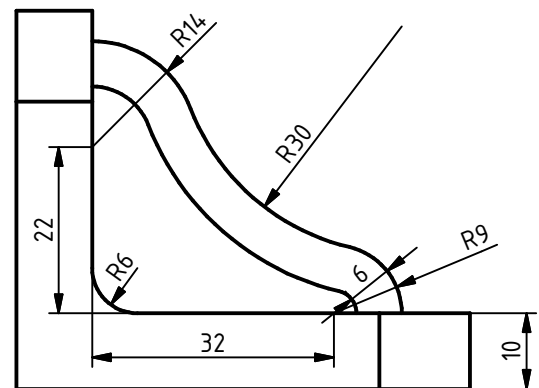
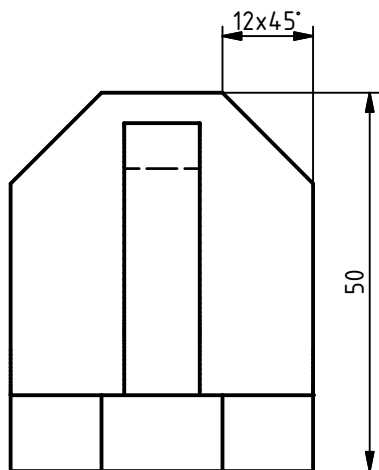

Realize a modelação do reforço através do Feature RIB.  
Utilize também o Chamfer e Fillet.

Designed by JoF	Checked by	Approved by - date	Date 01-05-2004	A4
JOF		<b>SuporteRib</b>		
		suportRib	Edition 1	Sheet 1 / 1

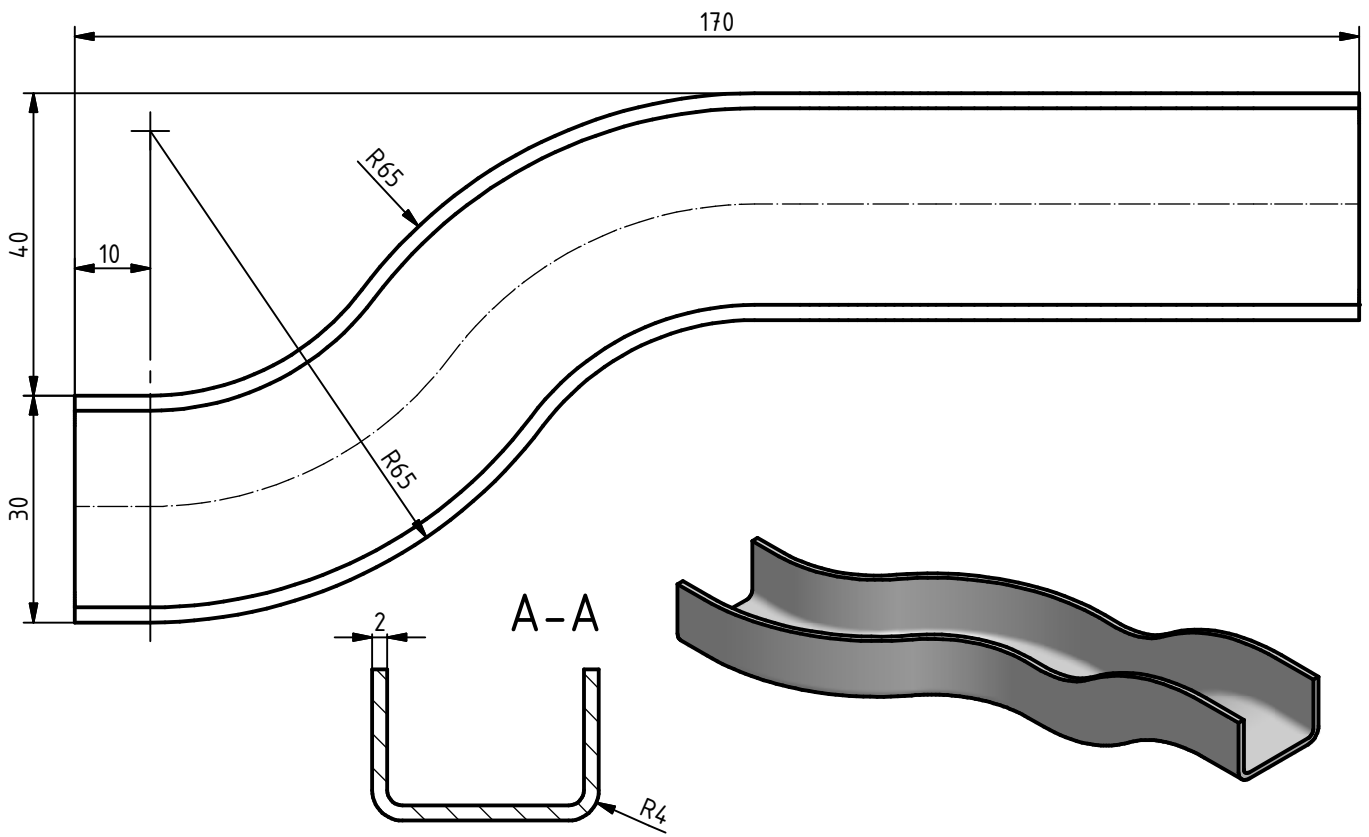
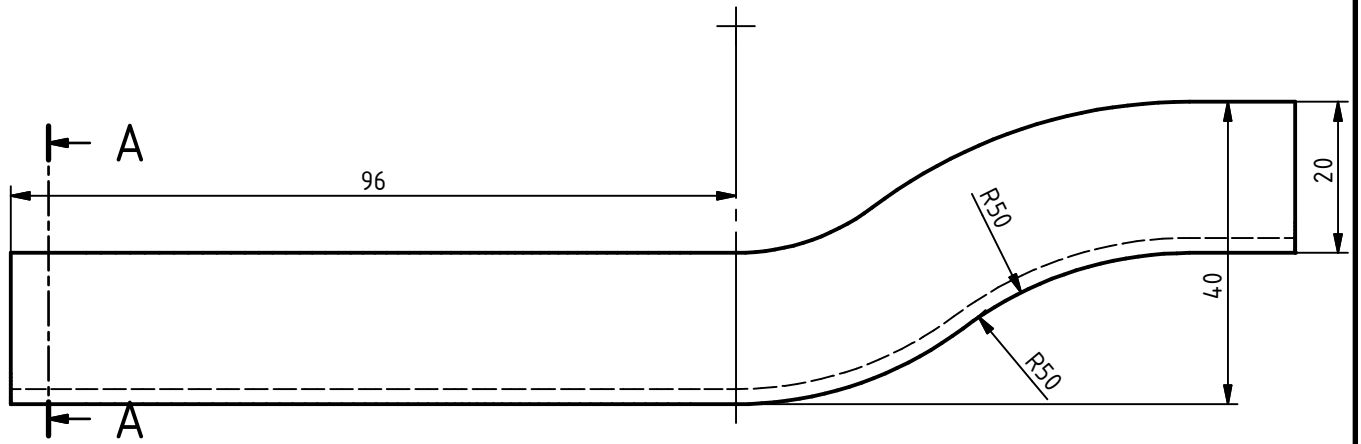



Designed by fonseca	Checked by	Approved by	Date		Date 23-09-2009	A4
FEUP/DEMEGI/SDI			PERFIL U TORTO			
ChapaUTorta			Edition		Sheet 1 / 1	

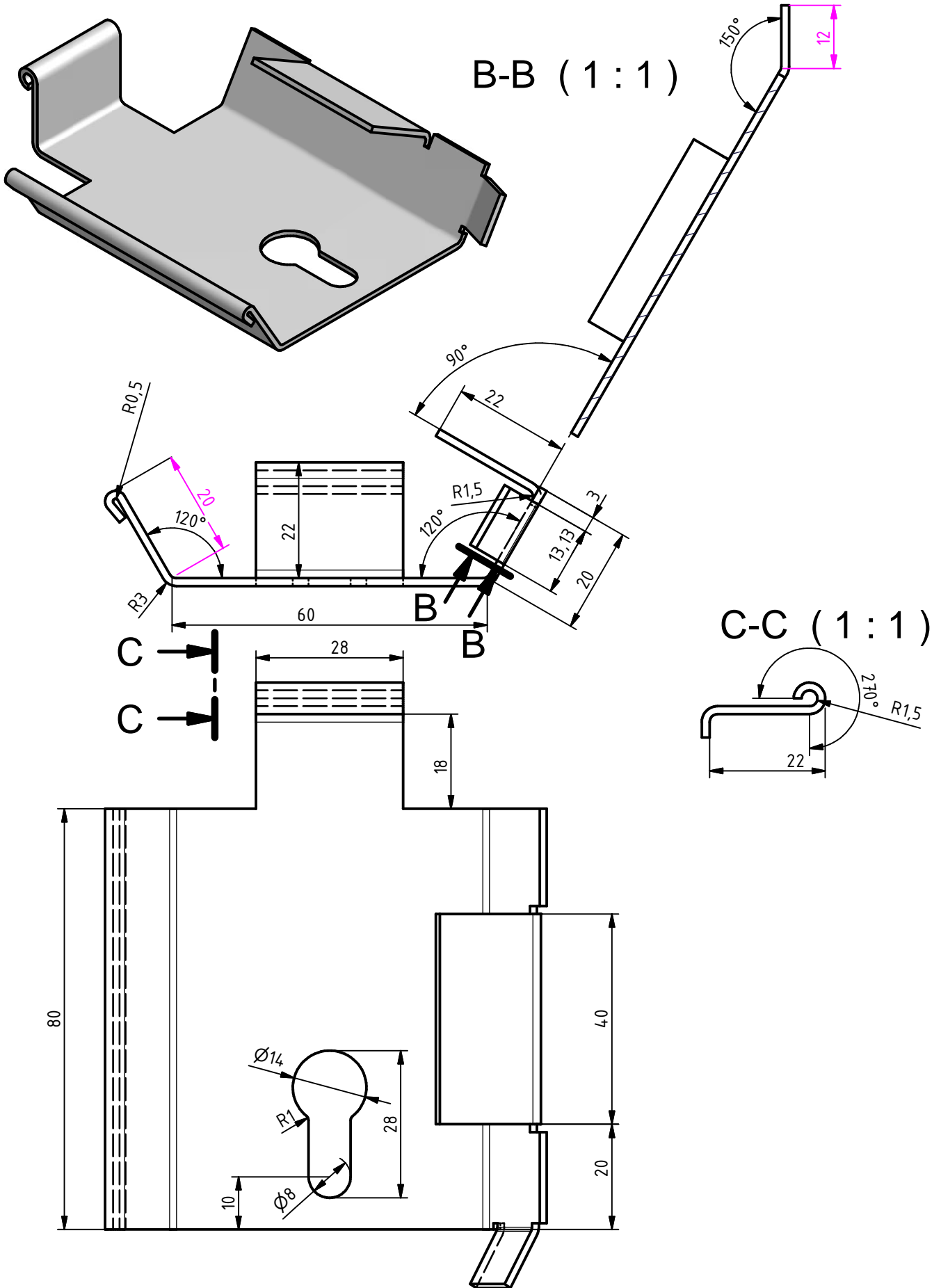

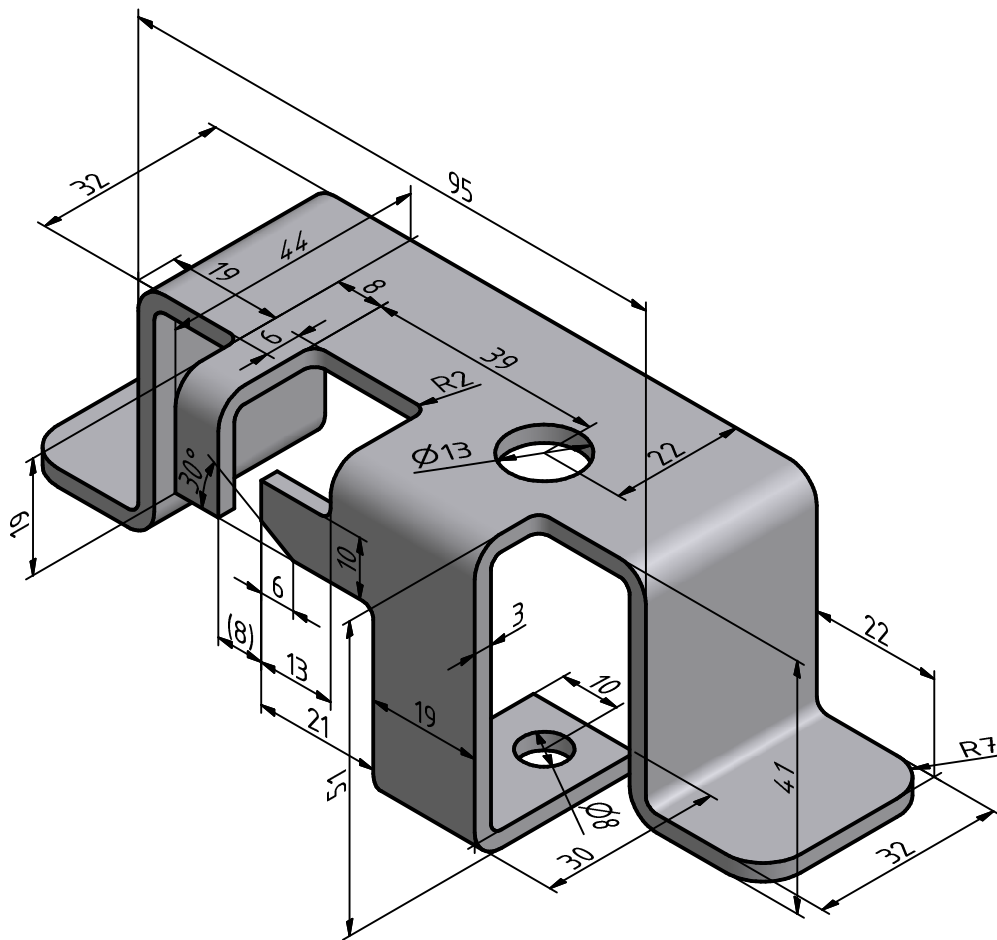

Designed by Joaquim Fonseca	Checked by	Approved by - date	Date 26-09-2009
 FEUP/DEMec/SDI	<b>CHAPA C/ "FEATURES"</b>		
	chapa02	Edition	Sheet 1 / 1



Designed by Joaquim Fonseca	Checked by	Approved by	Date	Date 26-09-2009	
 Universidade do Porto Faculdade de Engenharia FEUP	FEUP/DEMec/SDI		PEÇA EM CHAPA $t=3$		
	Chapat3		Edition	Sheet 1 / 1	

(1 : 2)

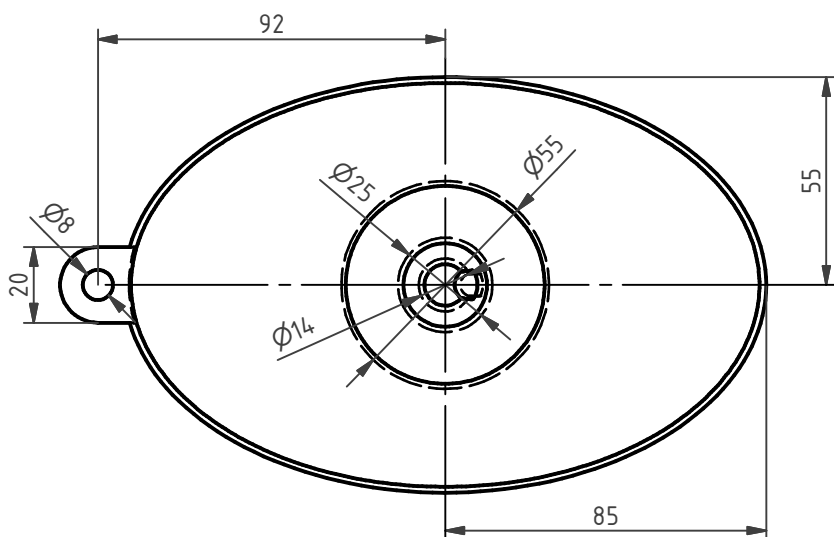
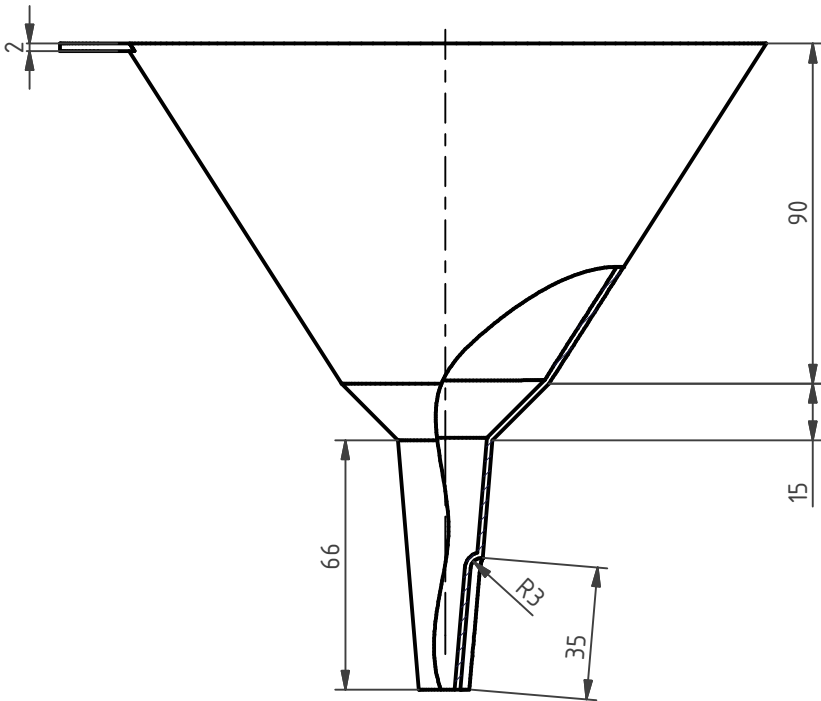
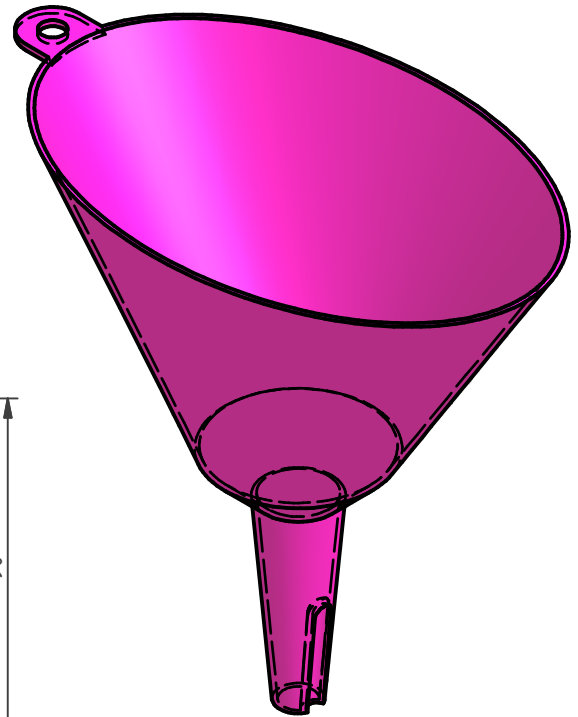

Espessura: 1,5 mm

Realizar com LOFT, REVOLVE e SHELL.

Designed by Joaquim Fonseca	Checked by	Approved by - date	Date 25-09-2009
 FEUP/DEMec/SDI	<b>FUNIL</b>		Sheet
	funil	Edition	1 / 1

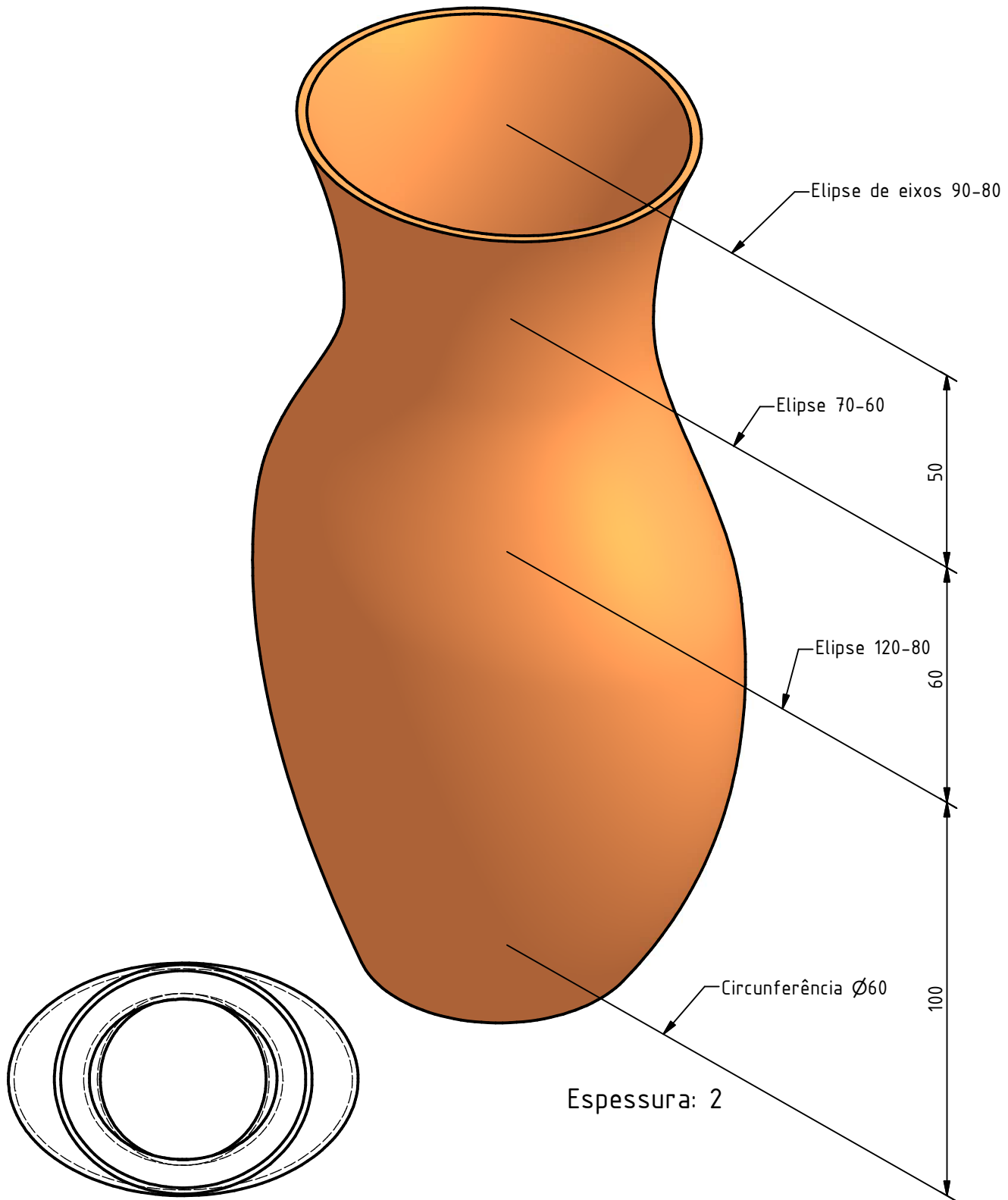

Designed by fonseca	Checked by	Approved by	Date		Date 03-10-2009	A4
Universidade do Porto Faculdade de Engenharia <b>FEUP</b>		FEUP/DEMec/SDI		JARRO		
Jarro1			Edition		Sheet 1 / 1	

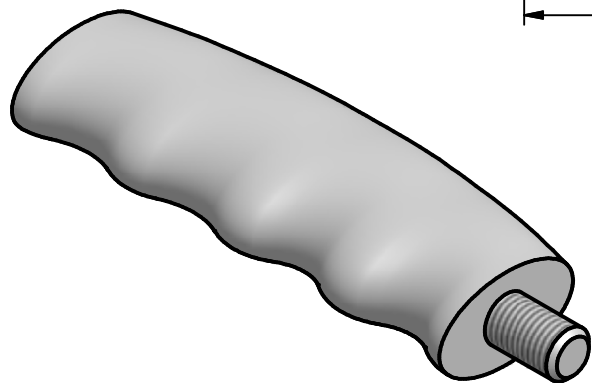
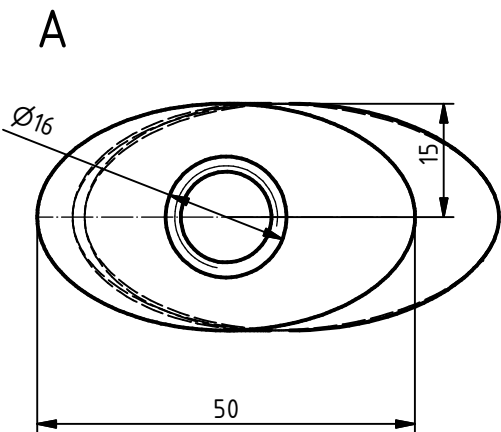
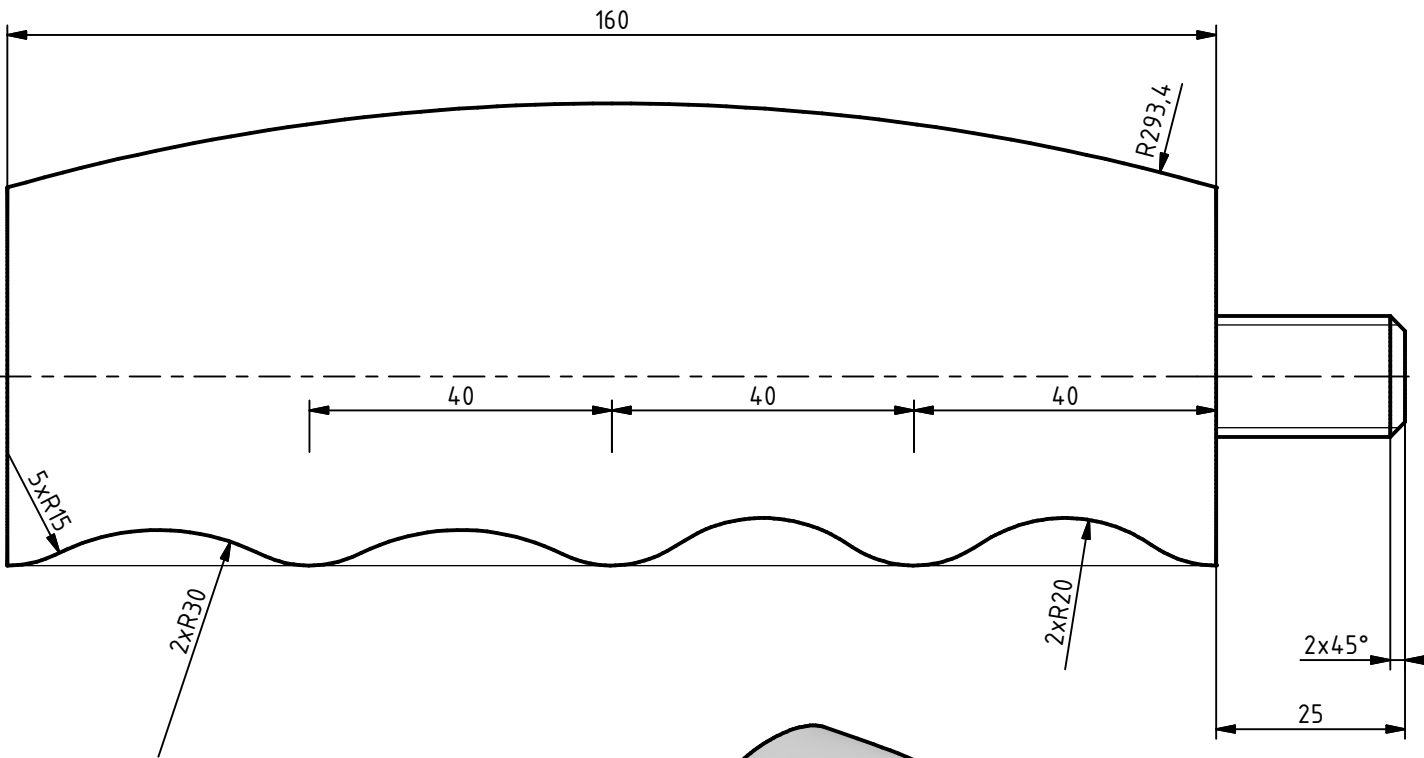
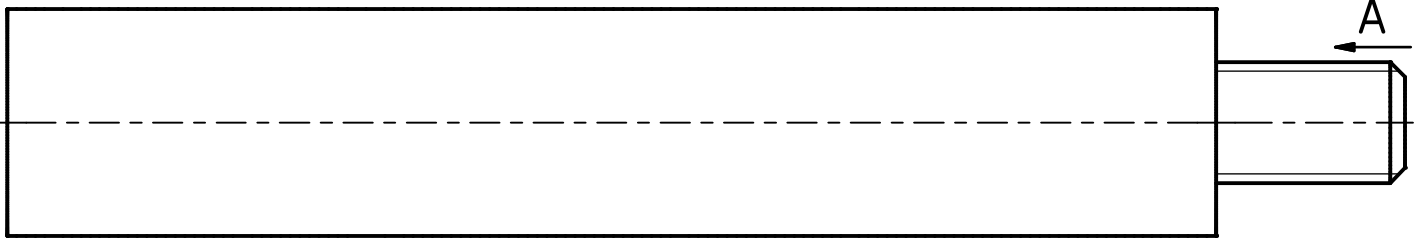

Designed by fonseca	Checked by	Approved by	Date		Date 21-09-2006	A4
FEUP/DEMEGI/SDI			PUNHO ERGONÓMICO			
Punho			Edition 1	Sheet 1 / 1		

A

**EQUAÇÕES:**

$nx = 2$   
 $ny = 4$   
 $dd = 8$   
 $comp_x = nx * dd$   
 $comp_y = ny * dd$

Espessura geral: 1  
 Espessura na parte lateral inferior: 1,5

Experimente alterar o número de pinos em X e em Y e verifique da adaptação correcta da peça

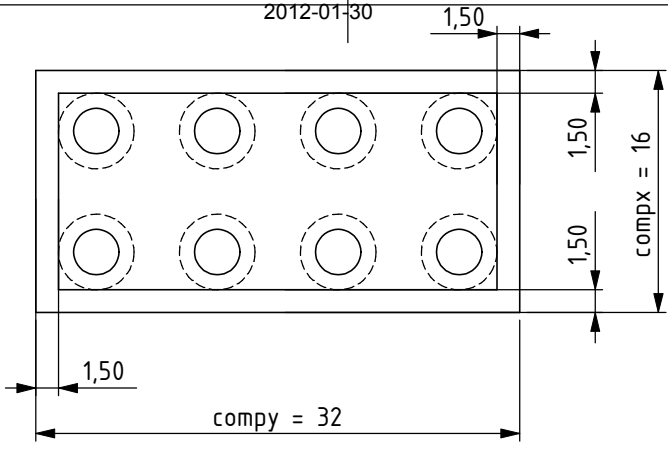

B

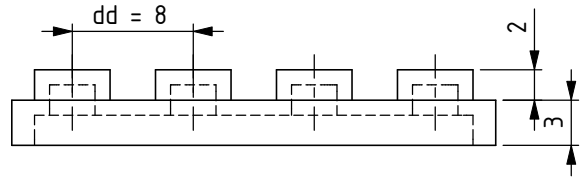

C

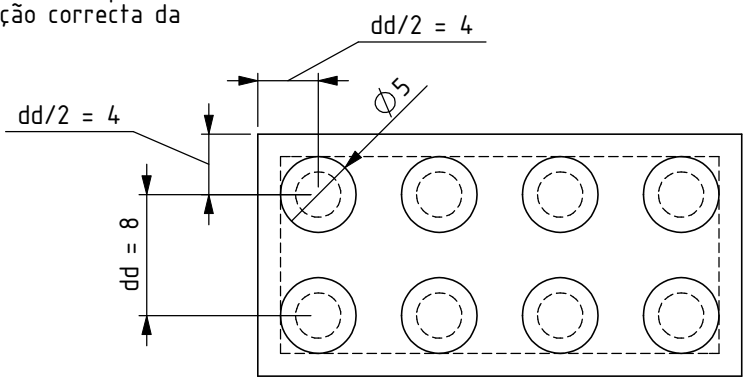

D

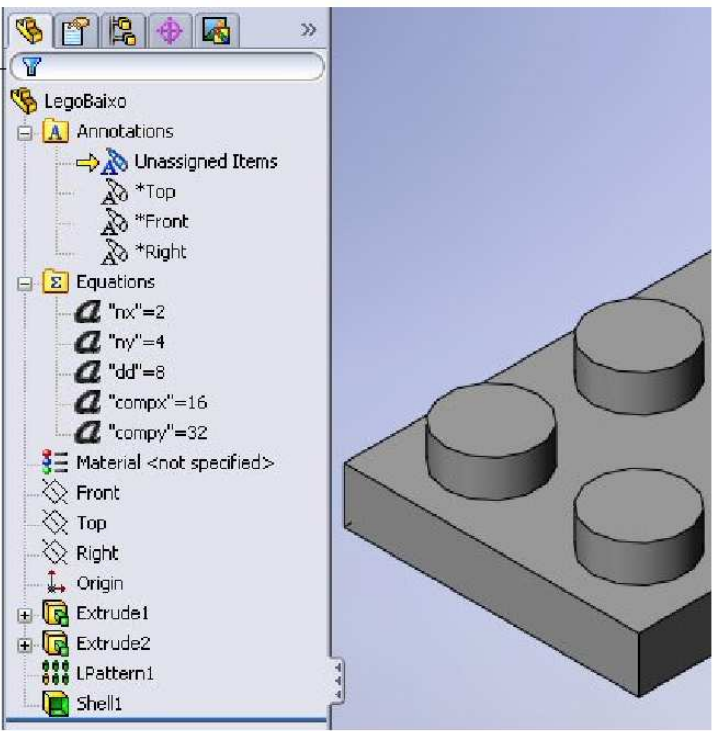

E

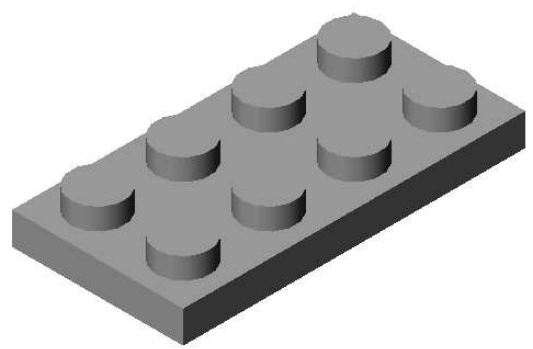

UNLESS OTHERWISE SPECIFIED:  
 DIMENSIONS ARE IN MILLIMETERS  
 SURFACE FINISH:  
 TOLERANCES:  
 LINEAR:  
 ANGULAR:

FINISH:

DEBUR AND  
 BREAK SHARP  
 EDGES

DO NOT SCALE DRAWING      REVISION

**FEUP/DEMEGI/SDI**

	NAME	SIGNATURE	DATE		
DRAWN	FONSECA		20-03-2009		
CHKD					
APPV'D					
MFG					
Q.A				MATERIAL: Geral	
				Quant.: 1	
				WEIGHT:	

TITLE:	<b>LEGO BAIXO</b>	
DWG NO.	<b>LegoBaixo</b>	A4
SCALE:1:1	SHEET 1 OF 1	

F

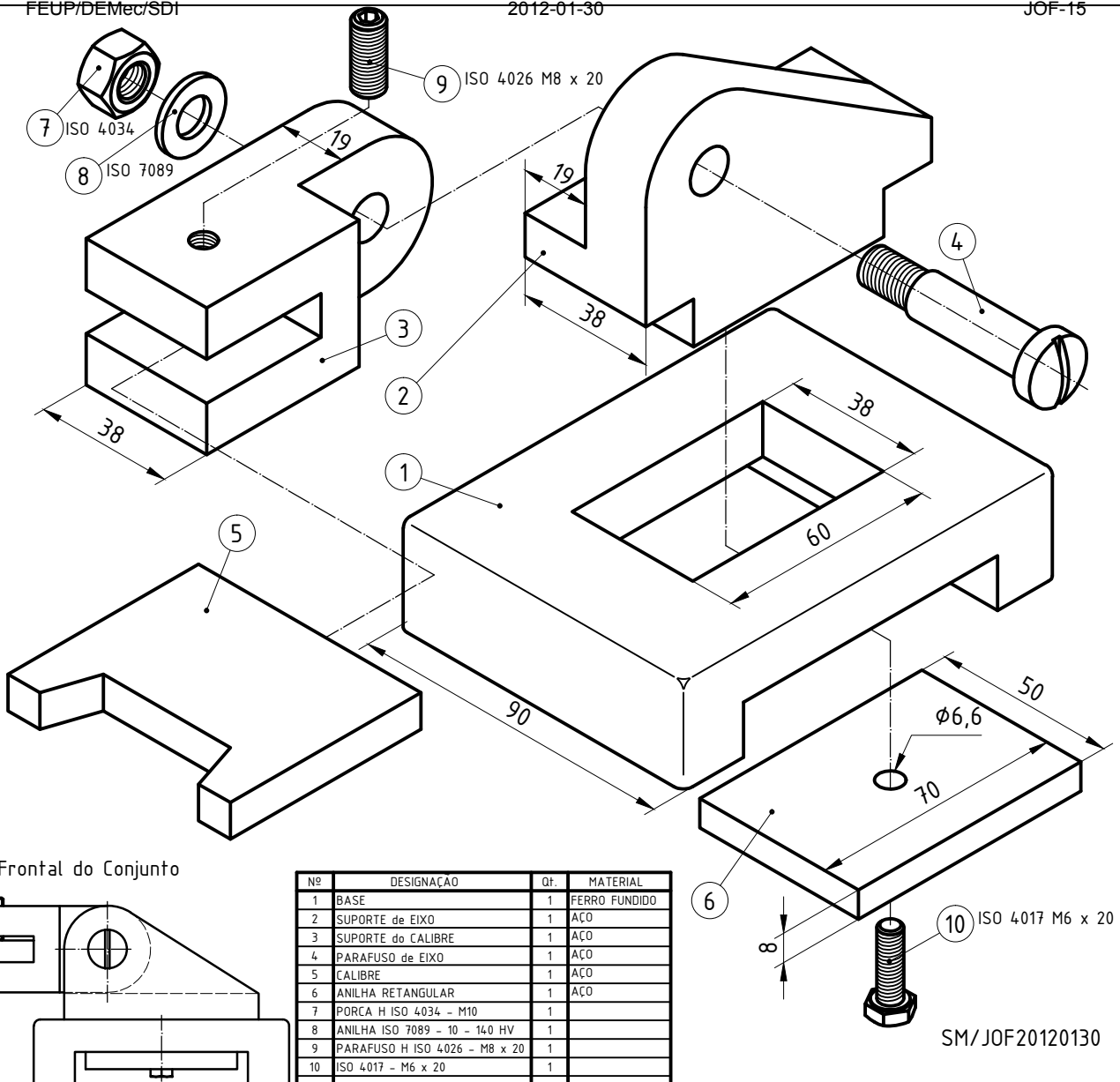

Vista Frontal do Conjunto

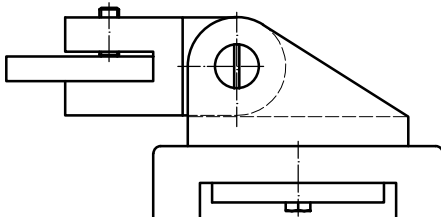

Nº	DESIGNAÇÃO	Qt.	MATERIAL
1	BASE	1	FERRO FUNDIDO
2	SUPORTE de EIXO	1	ÁÇO
3	SUPORTE do CALIBRE	1	ÁÇO
4	PARAFUSO de EIXO	1	ÁÇO
5	CALIBRE	1	ÁÇO
6	ANILHA RETANGULAR	1	ÁÇO
7	PORCA H ISO 4034 - M10	1	
8	ANILHA ISO 7089 - 10 - 140 HV	1	
9	PARAFUSO H ISO 4026 - M8 x 20	1	
10	ISO 4017 - M6 x 20	1	

SM/JOF20120130

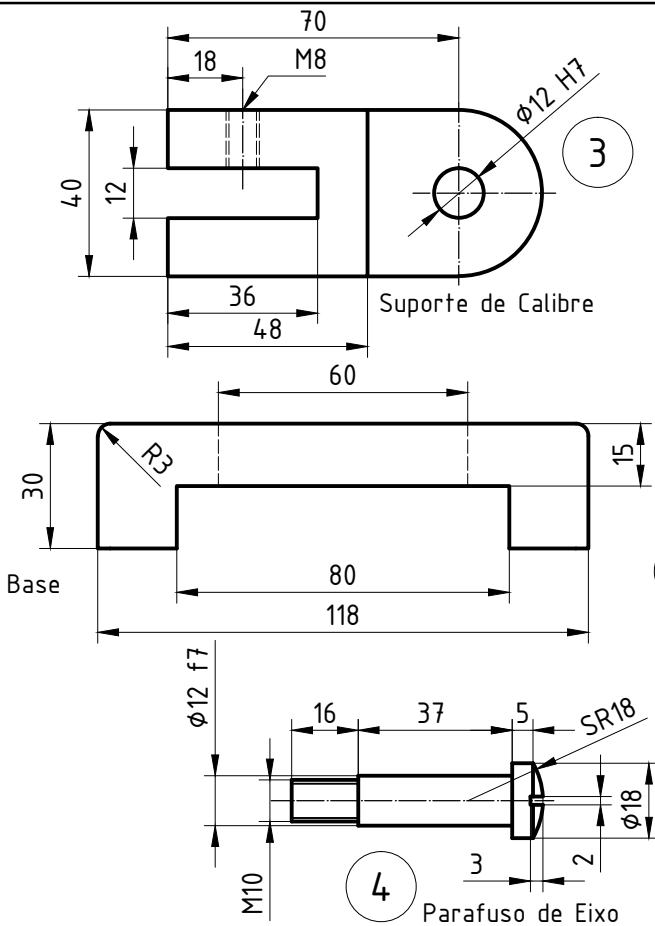

Uma vista de algumas peças (outras dimensões no explodido)

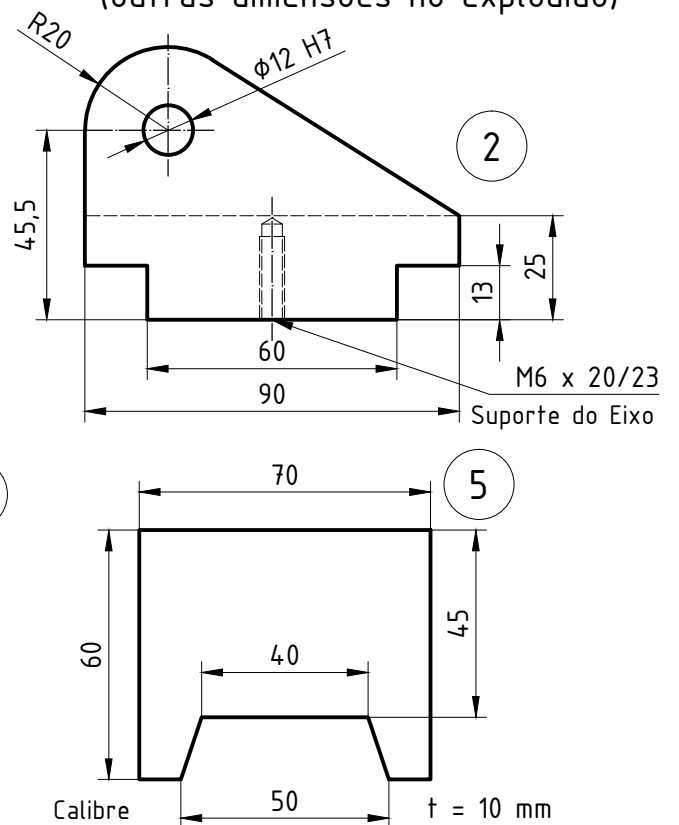

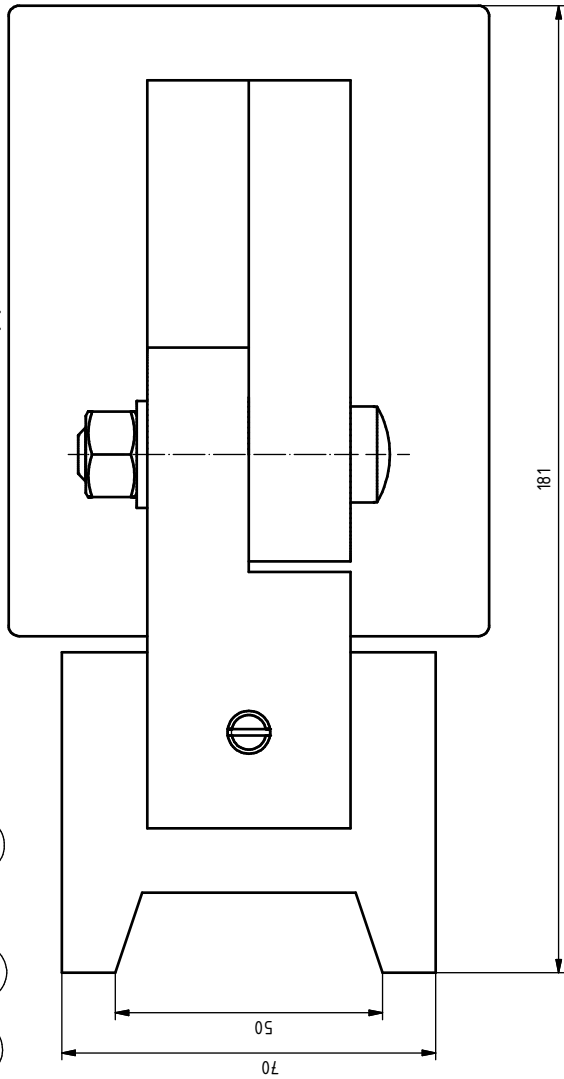
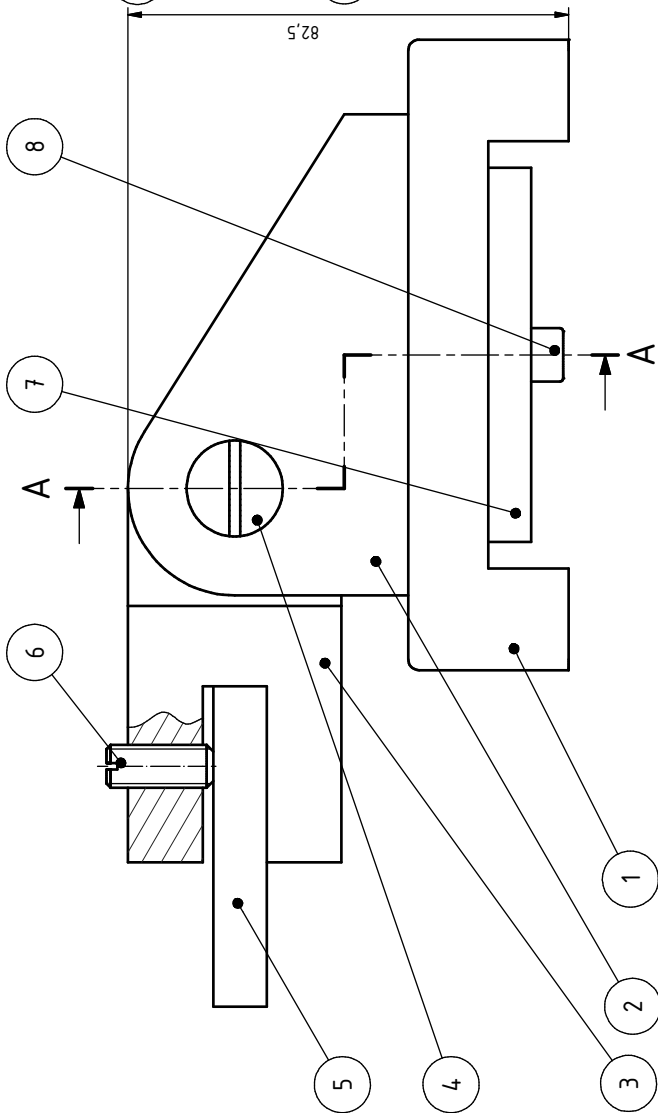
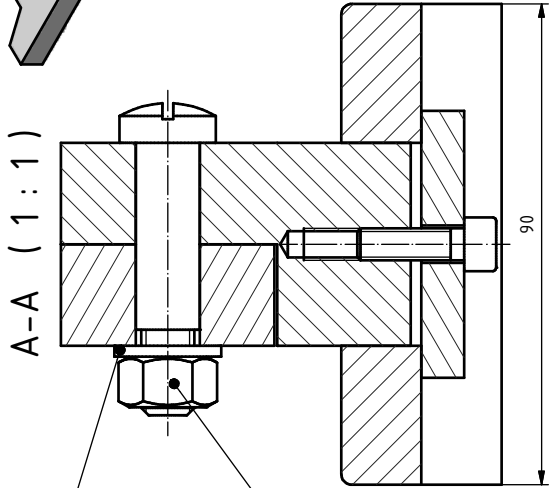
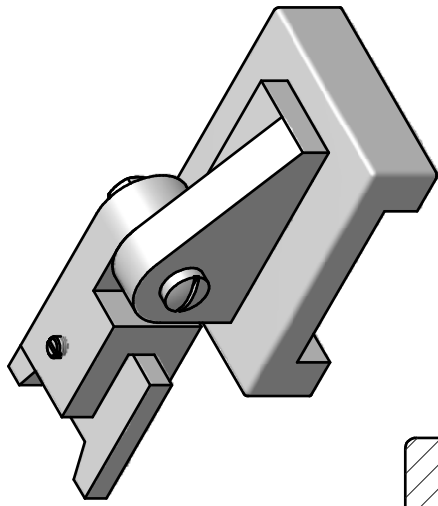

Lista de Peças

Nº	Qt.	PART NUMBER	Designação
1	1	base1	BASE
2	1	sup-eixo2	SUPORTE EIXO
3	1	sup-calibre3	SUPORTE ARTICULADO
4	1	sup-paraf4	PARAFUSO ARTICULAÇÃO
5	1	Calibre	CALIBRE
6	1	ISO 4766 - M8 x 20	Slotted Headless Set Screw - Flat Point
7	1	ChapaRec	CHAPA ANILHA
8	1	ISO 4762 - M6 x 20	Hexagon Socket Head Cap Screw
9	1	ISO 7089 - 10 - 14,0 HV	Washer
10	1	ISO 4034 - M10	Hex Nut

Designed by JOF

Checked by

Approved by - date

Date

03-05-2004

A3

SUPORTE DE CALIBRE

suportecalib

JOF

Edition 1

Sheet 1 / 1